



Model Number

NCB50-FP-E2-P4

Features

- Comfort series
- 50 mm flush
- 3-wire DC

Technical Data

General specifications

Switching element function		PNP NO contact
Rated operating distance	s_n	50 mm
Installation		flush
Output polarity		DC
Assured operating distance	s_a	0 ... 40.5 mm
Reduction factor r_{Al}		0.38
Reduction factor r_{Cu}		0.35
Reduction factor r_{304}		0.83

Nominal ratings

Operating voltage	U_B	10 ... 60 V DC
Switching frequency	f	0 ... 80 Hz
Hysteresis	H	typ. 3 %
Reverse polarity protection		reverse polarity protected
Short-circuit protection		pulsing
Voltage drop	U_d	≤ 3 V
Operating current	I_L	0 ... 200 mA
Off-state current	I_r	0 ... 0.5 mA
No-load supply current	I_0	≤ 20 mA
Time delay before availability	t_v	≤ 300 ms
Operating voltage indicator		LED, green
Switching state indicator		LED, yellow

Functional safety related parameters

MTTF _d	940 a
Mission Time (T_M)	20 a
Diagnostic Coverage (DC)	0 %

Ambient conditions

Ambient temperature	-25 ... 70 °C (-13 ... 158 °F)
---------------------	--------------------------------

Mechanical specifications

Connection type	screw terminals
Information for connection	A maximum of two conductors with the same core cross-section may be mounted on one terminal connection! tightening torque 1.2 Nm + 10 %
Core cross-section	up to 2.5 mm ²
Minimum core cross-section	without wire end ferrule 0.5 mm ² , with connector sleeves 0.34 mm ²
Maximum core cross-section	without wire end ferrule 2.5 mm ² , with connector sleeves 1.5 mm ²
Housing material	PBT
Sensing face	PBT
Housing base	metal
Degree of protection	IP68

Compliance with standards and directives

Standard conformity	
Standards	EN 60947-5-2:2007 IEC 60947-5-2:2007

Approvals and certificates

UL approval	cULus Listed, General Purpose
CSA approval	cCSAus Listed, General Purpose
CCC approval	Certified by China Compulsory Certification (CCC)

Dimensions

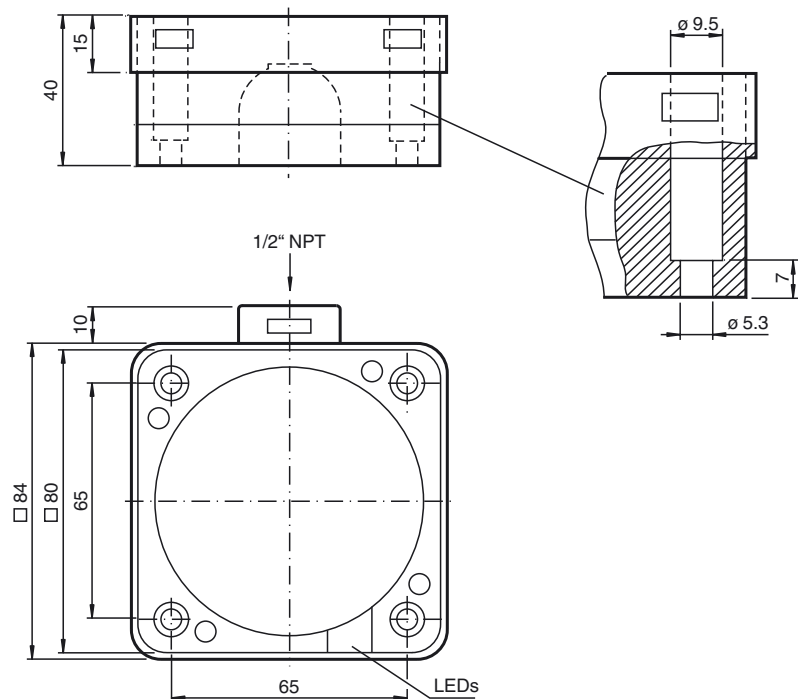

Electrical Connection

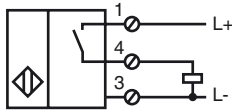

Installation Hint

These sensors are especially designed for embeddable mounting in conveyor floors. Due to its precise location in metal base plates the sensor is afforded a high degree of mechanical protection. No clearance is required between the sensor and the base plate, avoiding the need for protective guarding to prevent possible foot injury.

The large sensing range ensures positive detection, and thus provides consistent control and monitoring of the conveyor.

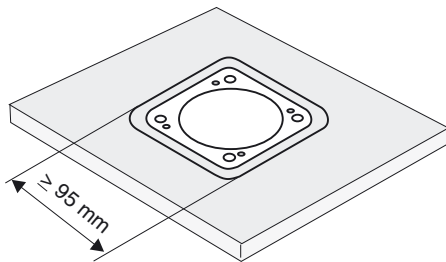

Warning!
Once the metal screening has been removed, the sensor can no longer be embeddable mounted.